

SPUTUM BOOTH

Essential for Infection Prevention During Sputum Collection

Introduction

Esco Sputum Collection Booth controls exposure risk to harmful aerosols / airborne diseases by providing containment using air flow to capture and exhaust out aerosols from sputum during expectoration, handling, or processing. We provide both operator / patient and environmental protection.

Key Features

- ISO Class 5 air cleanliness (Class 100 as per US Fed Std 209 E.)
- Negative pressure keeps aerosol contained in booth: Supplies 100% HEPA filtered / fresh air to the downflow plenum. Typical airflow is 85% total volume as downflow, 15% inflow and 100% exhausted.
- Fluorescent light fittings: T5 Lighting, 30W with diffuser for uniform lighting throughout the chamber.
- UV lamp operates on programmable timer embeded in the Sentinel™ Microprocessor System.

Construction

- Esco Sputum Collection Booth is made of either stainless steel 316 L grade or Electrogalvanized steel coated with **ISOCIDE™** antimicrobial coating finish sheetmetal.
- Stainless steel 316 L or Electrogalvanized steel coated with **ISOCIDE™** antimicrobial coating finish sheetmetal perforated grilles.
- Heavy-duty, durable stainless steel 316 L or Electrogalvanized steel coated with **ISOCIDE™** antimicrobial coating finish sheetmetal framed doors assembly with transparent glass windows.
- Reinforced stainless steel 316 L or SS304 finish sheetmetal floor
- Wall mounted stainless steel perforated work bench.
- Stainless steel leveling feet

Filtration System

- Room air is taken from the top of the booth through a washable pre-filter, air is forced evenly across the HEPA filter resulting in a clean downward airflow.
- Purified air travels downward within the interior in a vertical, downward stream with a velocity of 0.16 m/s and leaves the exhaust filter @ 0.60m/sec into the room close to front side wall.
- Supply and exhaust fan / filter systems will be individually designed for each location.

Control System Package

- Programmable UV timer.

Filtration Package

- Pre-Filter: A disposable G4 pre-filter with 85% arrestance and efficiency of 20% extends the life of the main filter.
- Downflow Filter: HEPA (H10)
- Main Supply Filter: HEPA (H10)
- Pre-exhaust Filter: HEPA (H14) filter on Esco Fan Filter Unit provides 99.995% at 0.3 microns at MPPS (Most Penetrating Particle Size).

Warranty

1 year warranty (excluding consumables). Consumables are ballast, fluorescent, and filters. The warranty will cover all other parts including the blower, speed controller, electrical main board, and microprocessor.

During the period of warranty, any repair, modification, testing and commissioning performed by any unauthorized party other than Esco Service Team shall void the warranty of the unit.



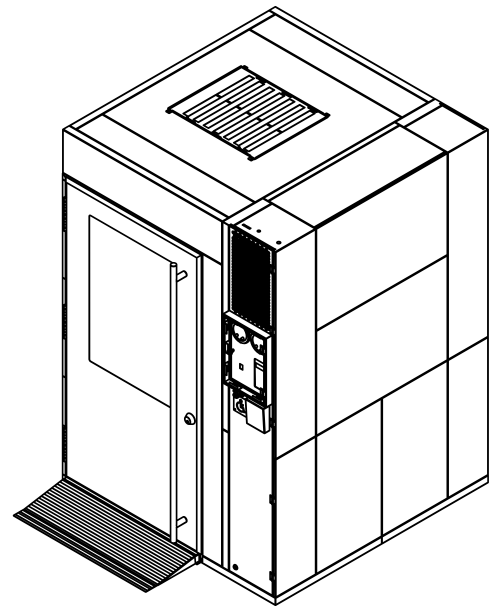
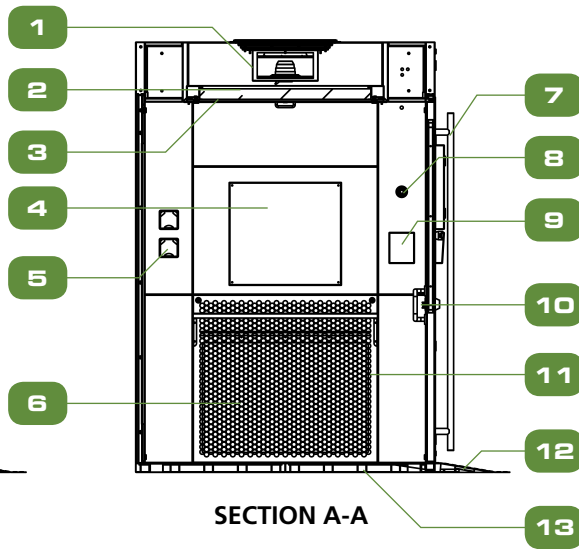
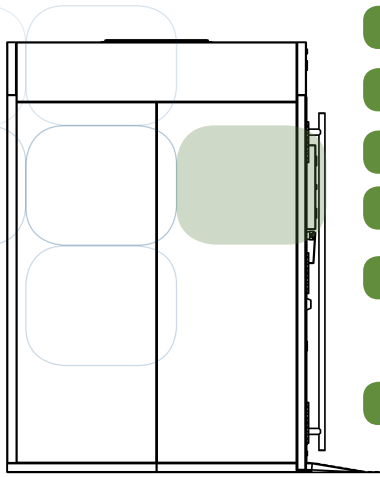

SECTION A-A

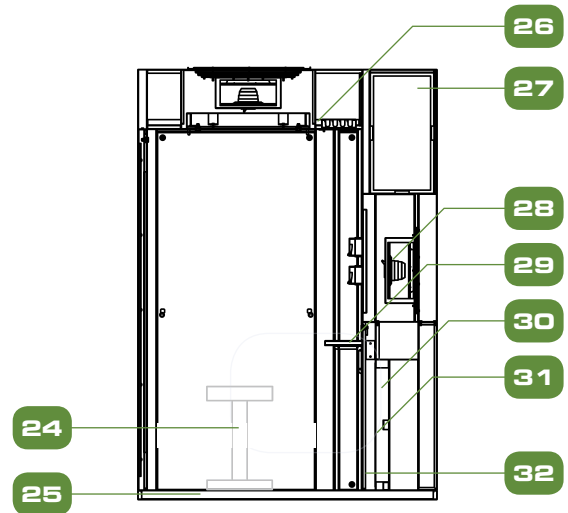
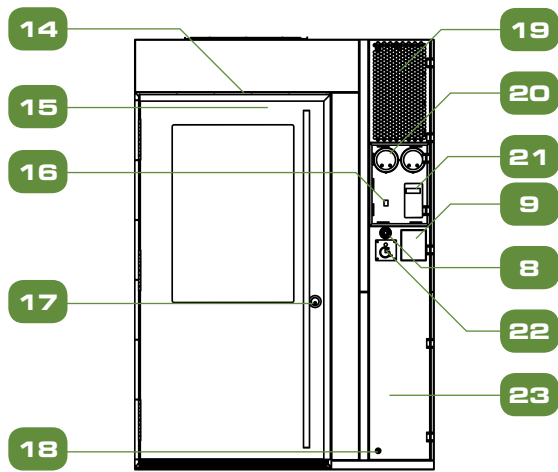

SECTION B-B

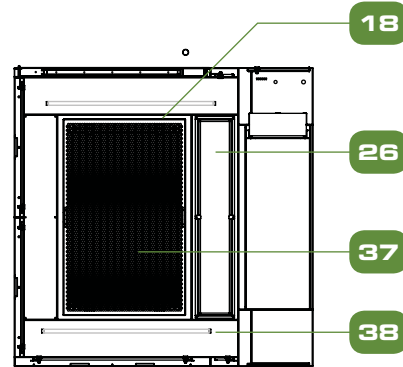
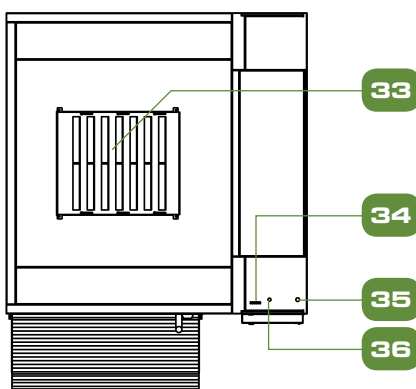

SECTION C-C

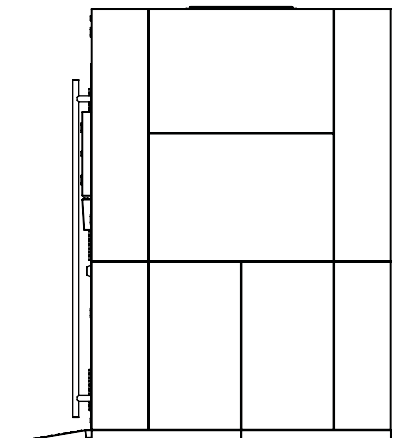

- | | | | |
|----------------------------------|--|------------------------|--------------------------------------|
| 1. Blower | 11. Hepa Filter Access Change | 20. Photohelic Gauge | 30. H10 Gel Seal Return Grill Filter |
| 2. H10 Gel Seal Downflow Filter | 12. SS Ramp | 21. Sentinel Control | 31. Filter Clamp |
| 3. Blower & Filter Access | 13. Hollow Section Base | 22. Handicap Symbol | 32. Perforated Grill |
| 4. Blower Access | 14. Concealed Door Closer | 23. Electrical Panel | 33. Pre-filter |
| 5. 13A-Gang Outlet IP Rated | 15. View Panel w/ Tempered Clear Glass | 24. SS Chair | 34. BMS Relay Signal |
| 6. Return Grill | 16. Unit On/Off Switch | 25. SS Flooring | 35. Power Chord |
| 7. SS Door Outside Longer Handle | 17. SS Door Lock & Key | 26. Led Lamp | 36. PMP Port Atmosphere. |
| 8. Emergency Stop | 18. SS Cam Latch | 27. H14 Exhaust Filter | 37. Downflow Diffuser |
| 9. Intercom | 19. Exhaust Grill | 28. Blower | 38. UV Lamp (Optional) |
| 10. SS Door Inside Handle | | 29. Perporated Table | |

SPUTUM BOOTH

• Esco Sputum Collection Booth

GUIDE TO MODELS

SB – S 115 150 193 – 1

Product Code	Material of Construction		Internal Width		Internal Dimension		Internal Height		Electrical Requirements	
Sputum Booth	Stainless Steel 304	S	1150 mm	115	1500 mm	150	1930 mm	193	220-240 V, AC, 50 HZ, 1Ø	1
	Stainless Steel 316	B	Customization	X	Customization	X	Customization	X	110-120 V, AC, 60 HZ, 1Ø	2
	Electro galvanized steel coated with ISOCIDE™ antimicrobial coating	A							220-240 V, AC, 60 HZ, 1Ø	3

GENERAL SPECIFICATION

Model	Sputum Collection Booth	
Nominal Size	1600 mm	
External Dimension (W x D x H)	1600 x 2000 x 2300 mm	
Internal Work Area Dimension (W x D x H)	1150 x 1500 x 1930 mm	
Cabinet Construction	Main Body	Stainless Steel Grade 316 L / Electro galvanized steel coated with ISOCIDE™ antimicrobial coating Sheetmetal
	Floor	Stainless Steel Grade 316 L / SS304
	Door	Stainless Steel Grade 316 L / Electro galvanized steel coated with ISOCIDE™ antimicrobial coating Sheetmetal
Power Consumption	350 W, FLA 7A	
Cabinet Full Load Amps (FLA)	10 Amp	
Fluorescent Lamp Intensity	500 lux	
Net Weight	725 kilogram	
Shipping Weight	1000 kg	
Shipping Dimension, Maximum (W x D x H)	2500 x 1250 x 2000 mm	

3

ADDITIONAL SPECIFICATION

Filter	G4 Pre-Filter, H10 Downflow Hepa Filter, H10 Return Grill Hepa Filter, H14 Exhaust Hepa Filter
Lights	UV & T5 Lighting
Work Bench	Detachable Stainless Steel
Leveling Feet	Concealed
Air Flow	100% Exhausted
ACH (AIR CHANGE PER HOUR):	105
CMH	350 m ³ /hr

Wheelchair can go inside together with the patient
Chamber is negative pressure

ESCO GLOBAL NETWORK

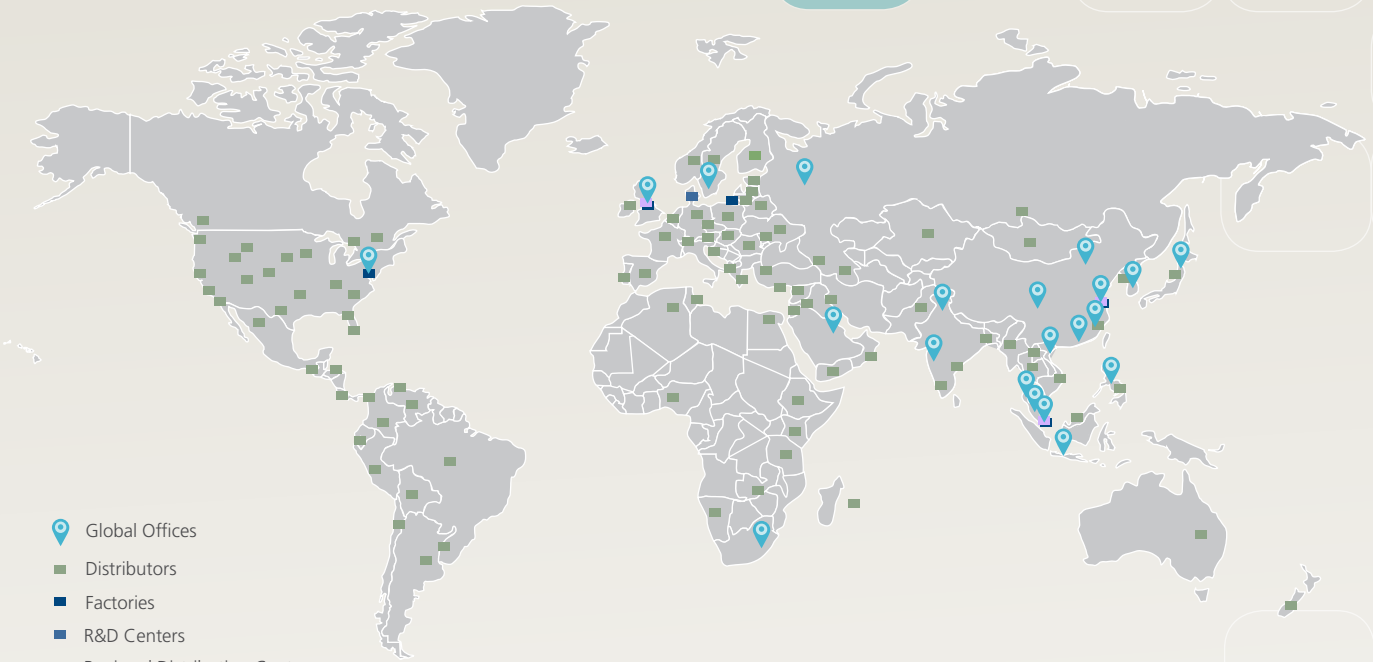

- Air Shower
- Aseptic Containment Isolator (ACTI)
- Ceiling Laminar Airflow Units
- Cleanroom Transfer Hatch
- Containment Barrier Isolator (CBI)
- Downflow Booth (DFB)
- Dynamic Floor Label Hatch
- Dynamic Pass Box
- Evidence Drying Cabinet
- Garment Storage Cabinet
- General Processing Platform Isolator (GPPI)
- Laminar Flow Horizontal Trolley
- Laminar Flow Straddle Units, Single and Double Laminar Flow Vertical Trolley
- Pass Box
- Soft Wall Cleanroom
- Sputum Booth
- Ventilated Balance Enclosure (VBE)
- Weighing and Dispensing Containment Isolator (WDCI)

Since 1978, Esco has emerged as a leader in the development of controlled environment, laboratory and pharmaceutical equipment solutions. Products sold in more than 100 countries include biological safety cabinets, fume hoods, ductless fume hoods, laminar flow clean benches, animal containment workstations, cytotoxic cabinets, hospital pharmacy isolators, and PCR cabinets and instrumentation. With the most extensive product line in the industry, Esco has passed more tests, in more languages, for more certifications, throughout more countries than any biosafety cabinet manufacturer in the world. Esco remains dedicated to delivering innovative solutions for the clinical, life science, research and industrial laboratory community. www.escoglobal.com.

ESCO

WORLD CLASS. WORLDWIDE.

Esco Technologies, Inc. • 2940 Turnpike Drive, Units 15-16 • Hatboro, PA 19040, USA
 Toll-Free USA and Canada 877-479-3726 • Tel 215-441-9661 • Fax 215-441-9660
us.escoglobal.com • usa@escoglobal.com

Esco Micro Pte. Ltd. • 21 Changi South Street 1 • Singapore 486 777
 Tel +65 6542 0833 • Fax +65 6542 6920 • mail@escoglobal.com
www.escoglobal.com

Esco Global Offices: Bahrain | Bangladesh | China | India | Indonesia | Italy | Japan
 Malaysia | Philippines | Russia | Singapore | South Africa | South Korea | Thailand
 United Kingdom | USA | Vietnam

